

AQUACLEAR

water treatment specialists

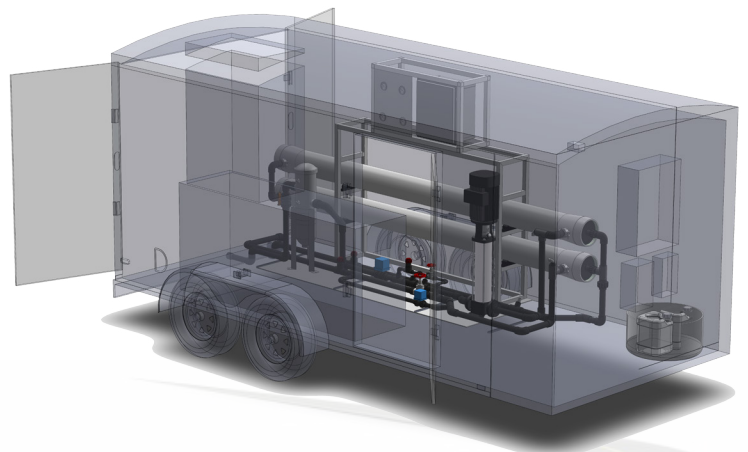

Mobile Filtration Reverse Osmosis System

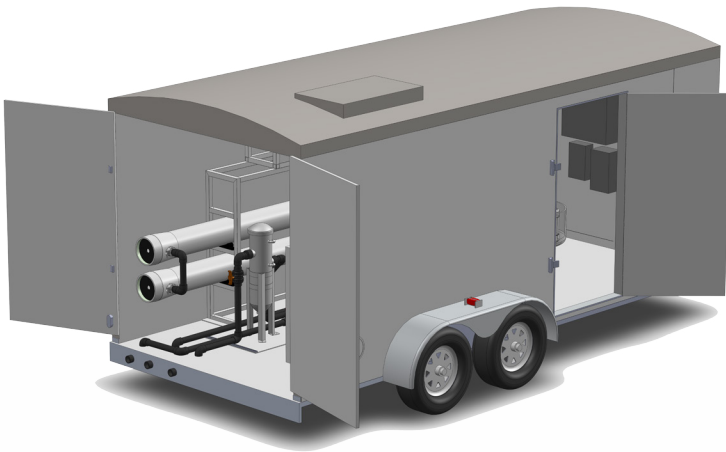

Mobile Reverse Osmosis System 16 ft. @ 40 GPM

Aqua Clear Water Treatment Specialists manufacturers and engineers standard and custom mobilized reverse osmosis systems to accommodate many different water conditions. Like each water type, each mobile water treatment system is unique and fully custom. When working with any customer we listen closely to the needs and expectations, then implement this in the design process for ease of use and maintenance. Each system is a high quality turn-key water treatment unit ready for use.

Features (standard)

- 8 ft. and 16 ft. mobile trailer
- Easy access points of connections
- Feed water connection
- Product water connection
- Waste water connection
- Interconnecting piping and wiring
- 110V/460V/3ph/60Hz power supply
- Plumbing and wiring mount/support
- Easy access control panel
- Full 3D/2D CAD drawings
- SCH 80 PVC plumbing

Features (optional)

- Lighting and electrical packages
- Clean-in-place skid (CIP)
- 380-415V/3ph/50Hz power supply
- 220V/3ph/60Hz power supply
- Chemical dosing systems
- Diamond plate flooring
- Interconnecting hoses

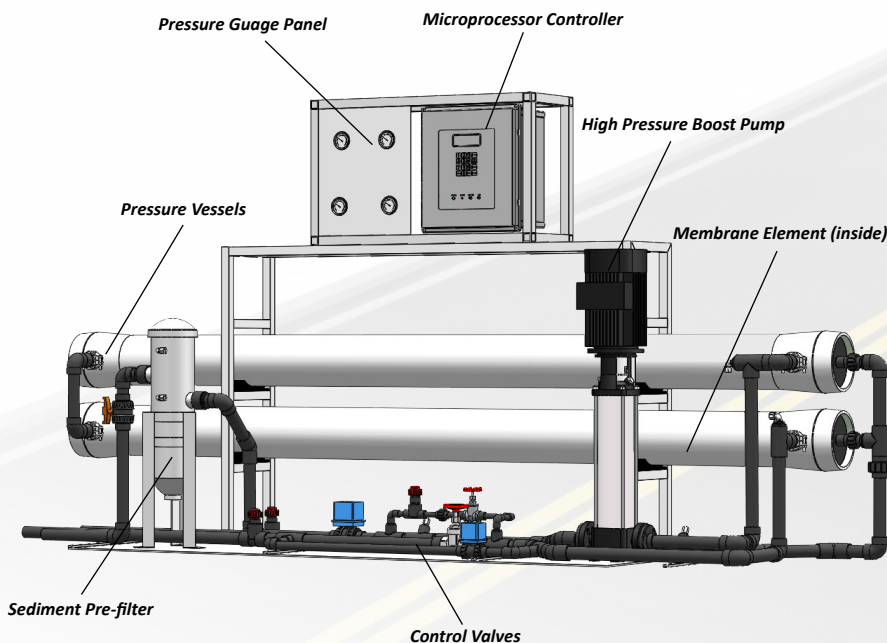

Aqua Clear Water Treatment Specialists

The Clear Choice for Commercial and Industrial Water Treatment Systems and Services

8451 Miralani Dr, Suite C • San Diego, CA 92126 • Ph. 858.270.7655 • Fax. 866.291.0742

AQUACLEAR

water treatment specialists



Mobile Filtration Reverse Osmosis System



Mobile Reverse Osmosis System 16 ft. @ 40 GPM

Applications

- Pool service
- Relief and rescue
- Agriculture and farming
- Small business
- Construction
- Window washing



> Local Control Panel



> Pre-Filtration

Aqua Clear Water Treatment Specialists also supplies: Multimedia Pretreatment, Activated Carbon Pretreatment, Water Conditioning, Chemical Dosing Systems, Ultraviolet (UV) Sterilizers and Ozonation Systems.

Aqua Clear Water Treatment Specialists

The Clear Choice for Commercial and Industrial Water Treatment Systems and Services

8451 Miralani Dr, Suite C • San Diego, CA 92126 • Ph. 858.270.7655 • Fax. 866.291.0742