

AQUACLEAR

water treatment specialists

Commercial Reverse Osmosis System

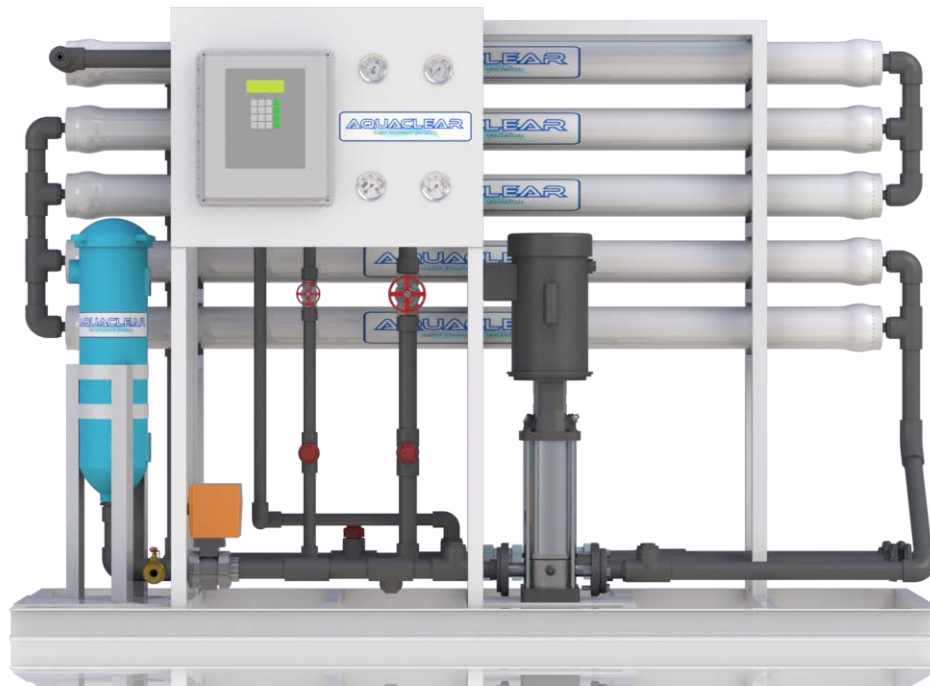

Aqua Clear Water Treatment Specialists manufacturers and engineers standard and custom commercial reverse osmosis systems water to accommodate many different water conditions. Like each water type, each commercial water treatment system is unique and fully customizable. When working with any customer we listen closely to the needs and expectations, then implement this in the design process for ease of use and maintenance. Designed to produce low dissolved solids water from tap or well water, these small commercial RO systems use high efficiency reverse osmosis membranes. These RO systems are designed to work at pressures of 150-250 psi for higher TDS water and use low-energy reverse osmosis membranes. Our line of commercial reverse osmosis membranes offer higher salt removal and the higher operating pressure overcomes the loss of membrane flow due to higher TDS level.

Features:

- | | |
|----------------------------------------------|-----------------------------------------------|
| Filter In/Out, Vessel In/Out Pressure Gauges | 2.5"/4" TFC spiral wound membranes |
| FRP Pressure Vessel (Fiberglass) | 220V/110V/1Ph/60Hz power supply |
| Heavy Duty High Pressure Tubing/Piping | Low Pressure and High Pressure Switch |
| Stainless Steel Flow Control Valves | Permeate, Concentrate and Recycle Flow Meters |
| Pretreatment Lockout | Product Water Quality Readout |
| Powder Coated Structural Steel Frame | Microprocessor RO Controller |
| Electric Actuated Inlet Ball Valve | Easy Access Control Panel |
| Heavy Duty 5 Micron Bag Pre-Filter | Factory Tested |
| Stainless Steel RO Booster Pump with Motor | Blending: Feed/Permeate |

(Options available)

Aqua Clear Water Treatment Specialists

The Clear Choice for Commercial and Industrial Water Treatment Systems and Services

8451 Miralani Dr, Suite C • San Diego, CA 92126 • Ph. 858.270.7655 • Fax. 866.291.0742

AQUACLEAR

water treatment specialists

Commercial Reverse Osmosis System

The AC Commercial Reverse Osmosis series can be customized based on individual design to include chemical dosing, cleaning skids, antiscalant, pre-filtration and more. These commercial reverse osmosis machines can accommodate between 600 and 30,000 GPD, with feed water TDS of 1,000 ppm to 6,000 ppm. Economical and efficient, Aqua Clear Water Treatment Specialists commercial reverse osmosis systems acquire the latest in RO technology to remove dissolved salts, particles, organics, minerals, solids and other contaminants from water. Our highly skilled engineers design each RO system utilizing membranes from the most reputable manufacturers such as TORAY, Dow Filmtec and Hydranautics.

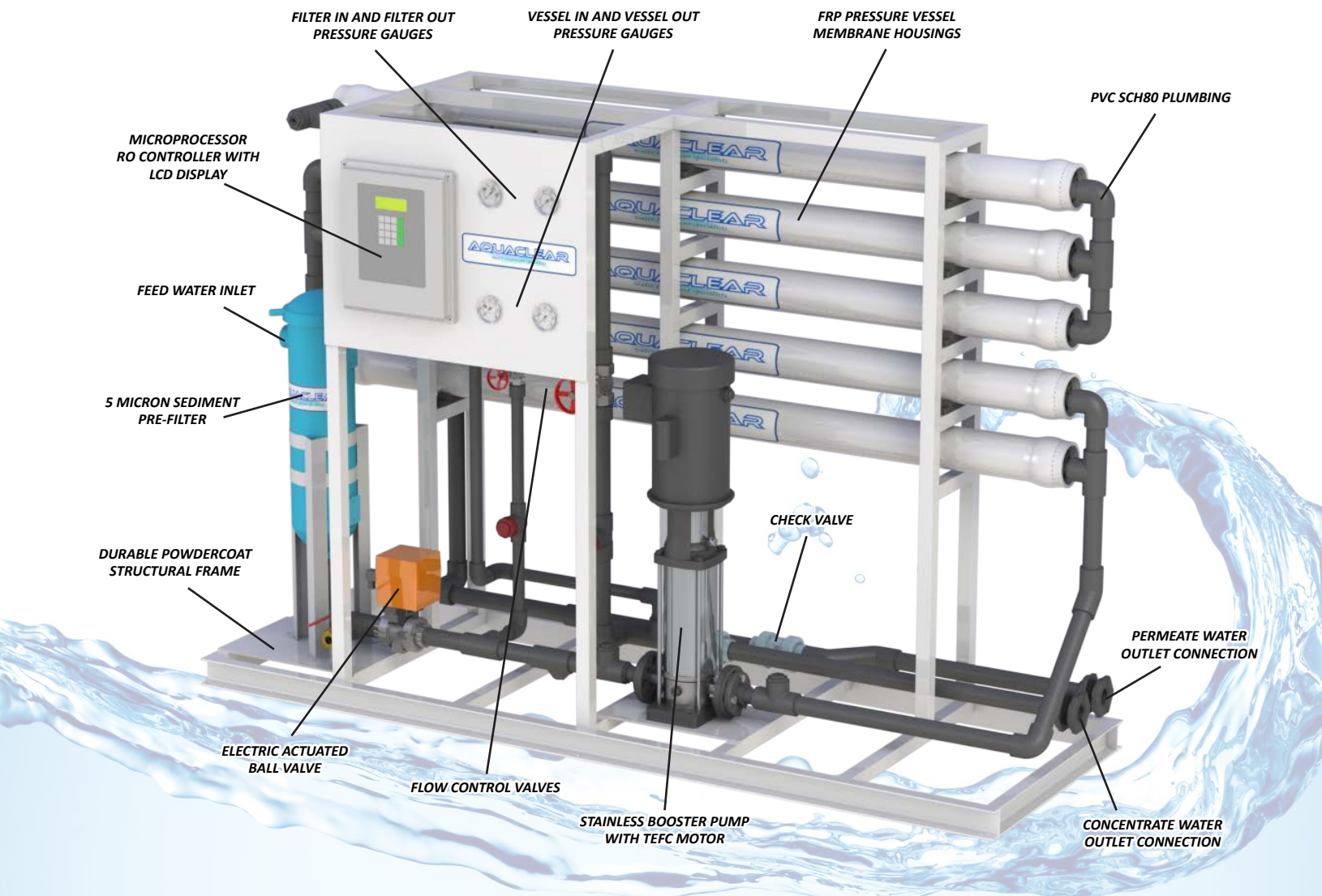

Aqua Clear Water Treatment Specialists also supplies: Multimedia Pretreatment, Activated Carbon Pretreatment, Water Conditioning, Chemical Dosing Systems, Ultraviolet (UV) Sterilizers and Ozonation Systems.

Aqua Clear Water Treatment Specialists

The Clear Choice for Commercial and Industrial Water Treatment Systems and Services

8451 Miralani Dr, Suite C • San Diego, CA 92126 • Ph. 858.270.7655 • Fax. 866.291.0742

AQUACLEAR

water treatment specialists

Commercial Reverse Osmosis System



Aqua Clear Water Treatment Specialists manufacturers and engineers standard and custom water treatment shipping containers to accommodate many different water conditions. Like each water type, each water treatment container is unique and fully customizable. When working with any customer we listen closely to the needs and expectations, then implement this in the design process for ease of use and maintenance. Each container is a fully turn-key system.

ACCRO-640-10K COMMERCIAL REVERSE OSMOSIS SYSTEM
10,000 GPD

Features (standard)

- Pre/post-treatment and pump pressure gauges
- FRP pressure vessel
- Heavy duty high pressure tubing/piping
- Corrosion resistant high pressure control valves
- Pretreatment lockout
- Powder coated carbon steel frame
- Electric inlet solenoid valve
- Heavy duty 5 micron cartridge pre-filter
- Corrosion resistant high pressure pump

- 2.5"/4" TFC spiral wound membranes
- 220V/110V/1Ph/60Hz power supply
- Low pressure switch
- Product, reject and recycle flow meters
- Product water quality readout
- Microprocessor RO controller
- Easy access control panel
- Factory tested
- Blending: feed/product

(Options available)

Aqua Clear Water Treatment Specialists

The Clear Choice for Commercial and Industrial Water Treatment Systems and Services

8451 Miralani Dr, Suite T • San Diego, CA 92126 • Ph. 858.270.7655 • Fax. 866.291.0742

Commercial Reverse Osmosis System

The AC Commercial Reverse Osmosis series can be customized based on individual design to include chemical dosing, cleaning skids, antiscalant, pre-filtration and more. These reverse osmosis machines can accommodate between 600 and 20,000 GPD, with feed water TDS of 1000 ppm to 5000 ppm. These features have the capability of removing hardness, chlorine, odors, color, iron, and sulfur. Economical and efficient, RO-200 commercial reverse osmosis systems acquire the latest in RO technology to remove dissolved salts, particles, organics, minerals, solids and other contaminants from water. Aqua Clear Water Treatment Specialists uses membranes from the most reputable manufacturers such as TORAY, Dow Filmtec and Hydranautics.

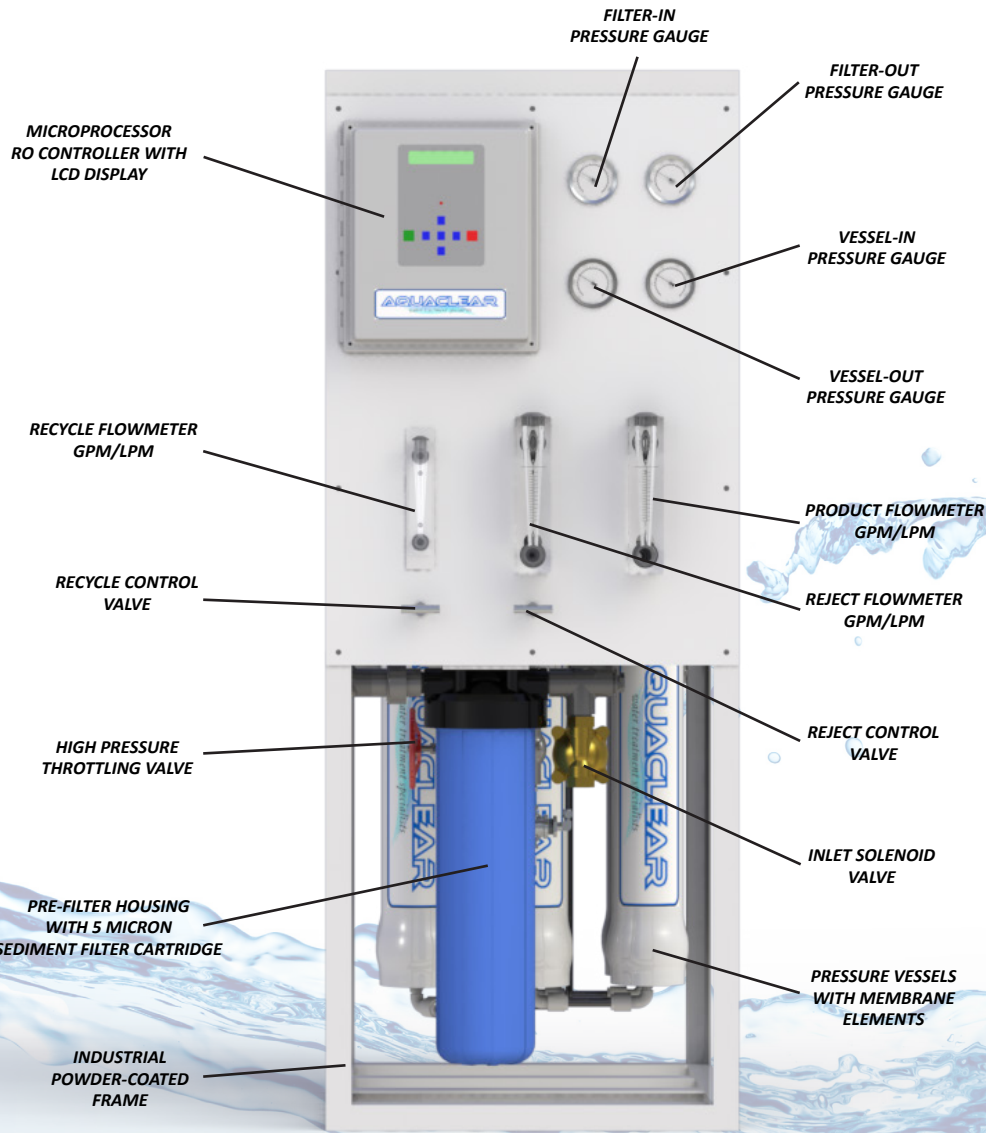

Aqua Clear Water Treatment Specialists also supplies: Multimedia Pretreatment, Activated Carbon Pretreatment, Water Conditioning, Chemical Dosing Systems, Ultraviolet (UV) Sterilizers and Ozonation Systems.

Aqua Clear Water Treatment Specialists

The Clear Choice for Commercial and Industrial Water Treatment Systems and Services

8451 Miralani Dr, Suite T • San Diego, CA 92126 • Ph. 858.270.7655 • Fax. 866.291.0742

Industrial Reverse Osmosis Systems



700 GPM Industrial Reverse Osmosis System w/SCADA PLC

Aqua Clear Water Treatment Specialists manufacturers and engineers 250-1000 gpm customized industrial reverse osmosis systems to accommodate many different water conditions. Like each water type, each reverse osmosis system is unique and fully customizable for our customers specific application. When working with any customer we listen closely to the needs and expectations, then implement this in the design process for ease of use and maintenance. Each reverse osmosis system comes fully complete with all wiring and plumbing making it a turn-key system. Simple plumbing connections and wiring is all that is needed.

Features (standard)

- Easy access points of connections
- Interconnecting piping and wiring
- Full electrical package
- 460V/3ph/60Hz power supply
- Plumbing and wiring mount/support
- Easy access control panel
- 3D/2D CAD drawings/O&M manual
- PLC controller
- Digital flow readouts
- Digital pressure readouts
- Permeate/feed conductivity monitor

Features (optional)

- Clean-in-place skid (CIP)
- 380-415V/3ph/50Hz power supply
- Chemical dosing systems
- Divert valves
- Permeate flush with valves
- PH/ORP monitoring
- SCADA with remote monitoring
- Ultraviolet Sterilizer

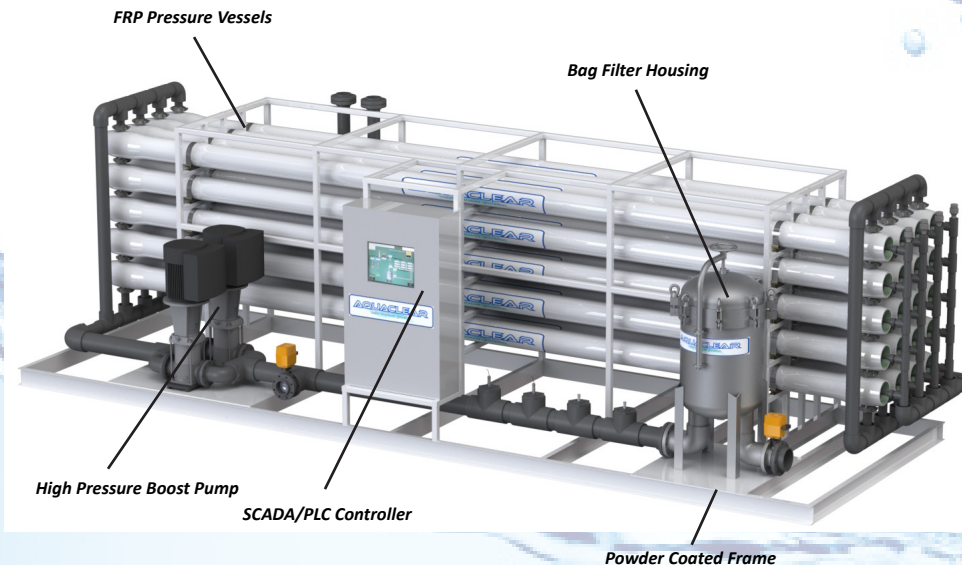

Aqua Clear Water Treatment Specialists, Inc.

Main office: 8451 Miralani Drive, Suite T, San Diego, CA 92126

Mailing Address: 3952 D Clairemont Mesa Blvd., #294, San Diego, CA 92117

Phone: 858-270-7655 • Fax: 866-291-0742 www.watertreatmentspecialists.com

Industrial Reverse Osmosis Systems

↳ Engineering ↳ Manufacturing ↳ Installation ↳ Startup/Training ↳ Service

Custom Engineered RO Plant Layouts

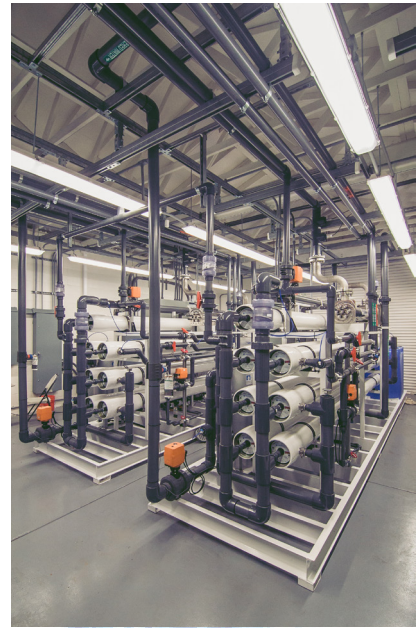

Benefits

When compared with other conventional water treatment processes, reverse osmosis has proven to be the most efficient means of removing salts, chemical contaminants and heavy metals, such as lead, from drinking water. Typically waters with total dissolved solids of 200 or more, reverse osmosis is less expensive than ion exchange. Compared with distillation, reverse osmosis use only a fraction of the total energy and does not have high temperature problems or scaling and corrosion. Today reverse osmosis systems have proven to be the most economical and efficient means of improving the quality of water.

Operation Specifications:

- ↳ Max. feed water temperature: 40°C/104°F
- ↳ Min. Feed water pressure: 30 psi
- ↳ Operating pressure: 120 to 150 psi
- ↳ Max. SDI (Silt Density Index): <3.0
- ↳ Max. feed chlorine : 0 ppm
- ↳ Turbidity < 50 max. 300 NTU
- ↳ Nominal system overall recovery rate 75%-80%
- ↳ Nominal system TDS reduction: 95%-99%

Aqua Clear Water Treatment Specialists also supplies: Multimedia Pretreatment, Activated Carbon Pretreatment, Water Conditioning, Chemical Dosing Systems, Ultraviolet (UV) Sterilizers and Ozonation Systems.

Aqua Clear Water Treatment Specialists, Inc.

Main office: 8451 Miralani Drive, Suite T, San Diego, CA 92126

Mailing Address: 3952 D Clairemont Mesa Blvd., #294, San Diego, CA 92117

Phone: 858-270-7655 • Fax: 866-291-0742 www.watertreatmentspecialists.com

AQUACLEAR

water treatment specialists

Clean-In-Place System CIP Skid



ACCIP CLEAN-IN-PLACE MEMBRANE CLEANING SYSTEM



Aqua Clear Water Treatment Specialists manufacturers and engineers standard and custom clean-in-place membrane cleaning skids. Membrane cleaning systems are designed to be used with any RO system to clean membranes without removing them from the system. When working with any customer we listen closely to the needs and expectations, then implement this in the design process for ease of use and maintenance. Each container is a fully turn-key system.

Features (standard)

- Closed Top Cleaning Solution Tank
- Centrifugal Transfer Pump with TEFC Motor
- Sediment Cartridge Filter Housing
- Pre-Wired control panel with H/O/A
- NEMA-4 Electrical Enclosure
- Low Tank Level Switch for Automatic Shutdown
- Temperature Indicator
- Flow Indicator
- Corrosion resistant pump

- Manual Recirculation Line for Solution Mixing
- Manual Tank Drain Valve

(Options available)

- pH Monitor
- Immersion Heater with Adjustable Thermostat
- CPVC Piping
- Portability for Skid Systems (Hose Kit & Caster Wheels)

Aqua Clear Water Treatment Specialists

The Clear Choice for Commercial and Industrial Water Treatment Systems and Services

8451 Miralani Dr, Suite C • San Diego, CA 92126 • Ph. 858.270.7655 • Fax. 866.291.0742



Clean-In-Place System CIP Skid

The membrane in reverse osmosis elements can become fouled by suspended solids, microorganisms, and mineral scale. These deposits build up during operation and cause loss in water output or salt rejection, or both. Regular cleaning of the membrane elements minimizes the loss of performance and extends membrane life. Maintain System Performance at a higher level by cleaning membranes regularly. Also by utilizing our clean-in-place skid you are able to clean membranes without have to remove them from your system to reduce maintenance and downtime of the reverse osmosis system. Systems are designed to work with all types of membrane cleaning procedures including inorganic mineral scale (low pH), biological/organic fouling (high pH), and sanitization cycles.

Each system includes a cleaning solution tank, transfer pump, and sediment filter to trap debris from re-entering the membranes during recirculation. All steps of the CIP process are to be performed manually by an equipment operator. All CIP equipment including the cleaning solution tank are factory mounted, pre-piped, and pre-wired on a dedicated skid assembly. The Skid Mounted configuration is a good choice for installations where multiple RO systems are in place or where a hard piped CIP system is desired. This option can also be modified for portability for easy movement to storage or other locations within the plant.

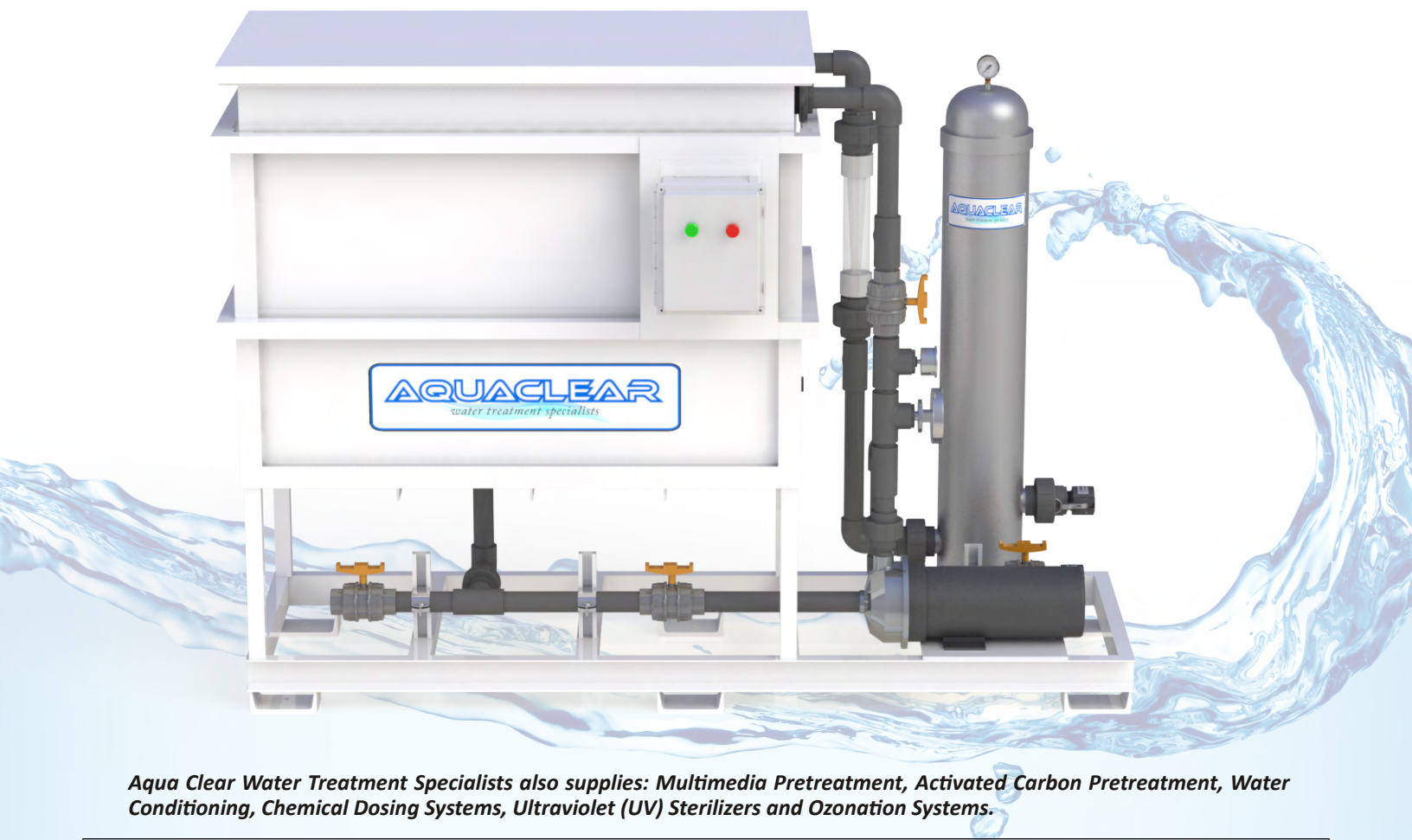

Aqua Clear Water Treatment Specialists also supplies: Multimedia Pretreatment, Activated Carbon Pretreatment, Water Conditioning, Chemical Dosing Systems, Ultraviolet (UV) Sterilizers and Ozonation Systems.

Aqua Clear Water Treatment Specialists

The Clear Choice for Commercial and Industrial Water Treatment Systems and Services

8451 Miralani Dr, Suite C • San Diego, CA 92126 • Ph. 858.270.7655 • Fax. 866.291.0742

AQUACLEAR

water treatment specialists



Mobile Filtration Reverse Osmosis System

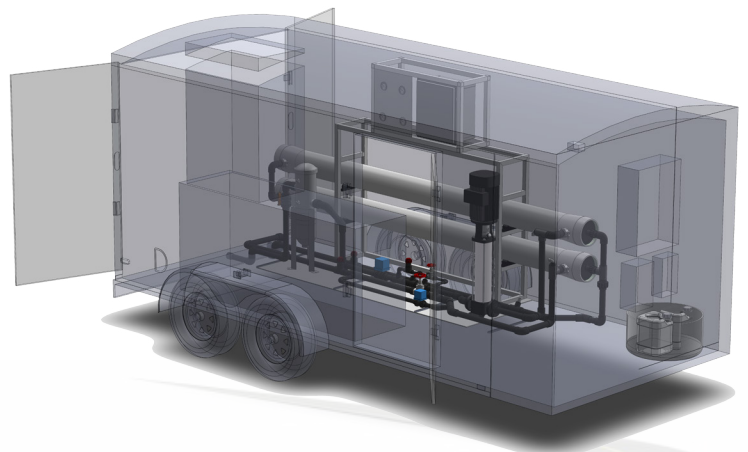
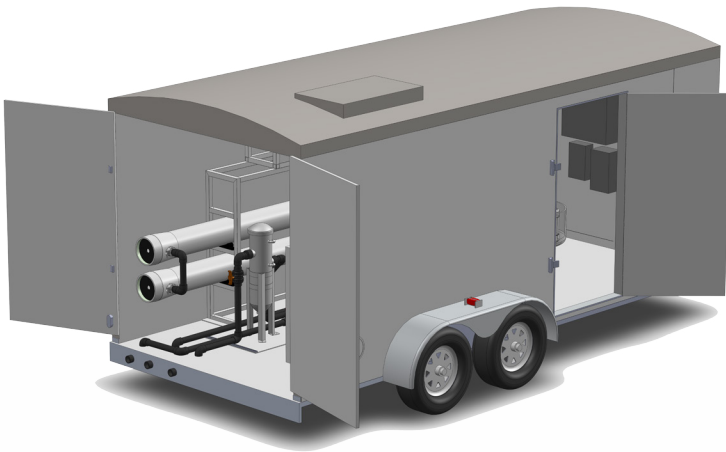

Mobile Reverse Osmosis System 16 ft. @ 40 GPM

Aqua Clear Water Treatment Specialists manufacturers and engineers standard and custom mobilized reverse osmosis systems to accommodate many different water conditions. Like each water type, each mobile water treatment system is unique and fully custom. When working with any customer we listen closely to the needs and expectations, then implement this in the design process for ease of use and maintenance. Each system is a high quality turn-key water treatment unit ready for use.

Features (standard)

- 8 ft. and 16 ft. mobile trailer
- Easy access points of connections
- Feed water connection
- Product water connection
- Waste water connection
- Interconnecting piping and wiring
- 110V/460V/3ph/60Hz power supply
- Plumbing and wiring mount/support
- Easy access control panel
- Full 3D/2D CAD drawings
- SCH 80 PVC plumbing

Features (optional)

- Lighting and electrical packages
- Clean-in-place skid (CIP)
- 380-415V/3ph/50Hz power supply
- 220V/3ph/60Hz power supply
- Chemical dosing systems
- Diamond plate flooring
- Interconnecting hoses

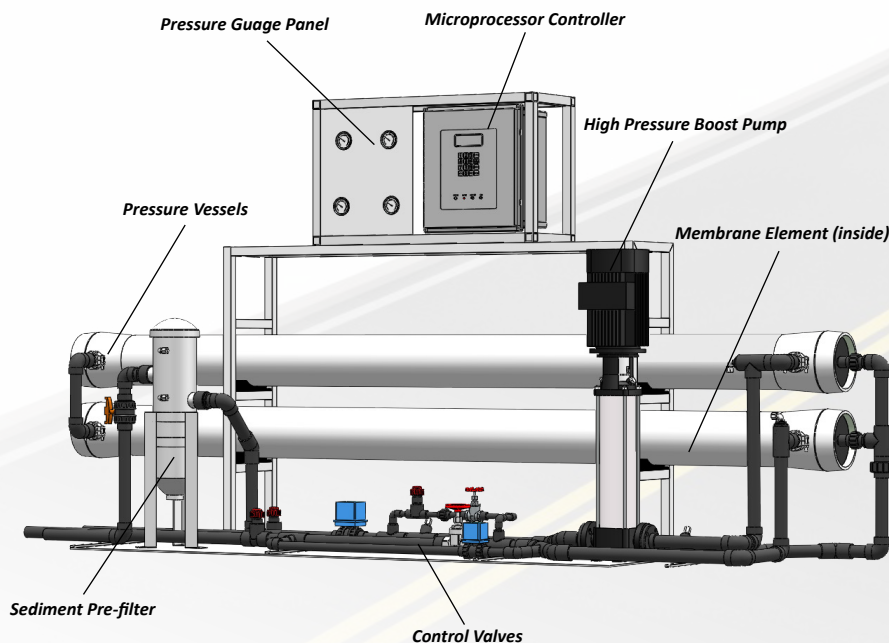

Aqua Clear Water Treatment Specialists

The Clear Choice for Commercial and Industrial Water Treatment Systems and Services

8451 Miralani Dr, Suite C • San Diego, CA 92126 • Ph. 858.270.7655 • Fax. 866.291.0742

AQUACLEAR

water treatment specialists



Mobile Filtration Reverse Osmosis System



Mobile Reverse Osmosis System 16 ft. @ 40 GPM

Applications

- Pool service
- Relief and rescue
- Agriculture and farming
- Small business
- Construction
- Window washing



> Local Control Panel



> Pre-Filtration

Aqua Clear Water Treatment Specialists also supplies: Multimedia Pretreatment, Activated Carbon Pretreatment, Water Conditioning, Chemical Dosing Systems, Ultraviolet (UV) Sterilizers and Ozonation Systems.

Aqua Clear Water Treatment Specialists

The Clear Choice for Commercial and Industrial Water Treatment Systems and Services

8451 Miralani Dr, Suite C • San Diego, CA 92126 • Ph. 858.270.7655 • Fax. 866.291.0742